

Jan. 4, 1949.

J. D. HARLIN  
STRING MUSICAL INSTRUMENT WITH  
CHORD TUNING MECHANISM

2,458,263

Filed Aug. 21, 1947

3 Sheets-Sheet 1

FIG. 1.

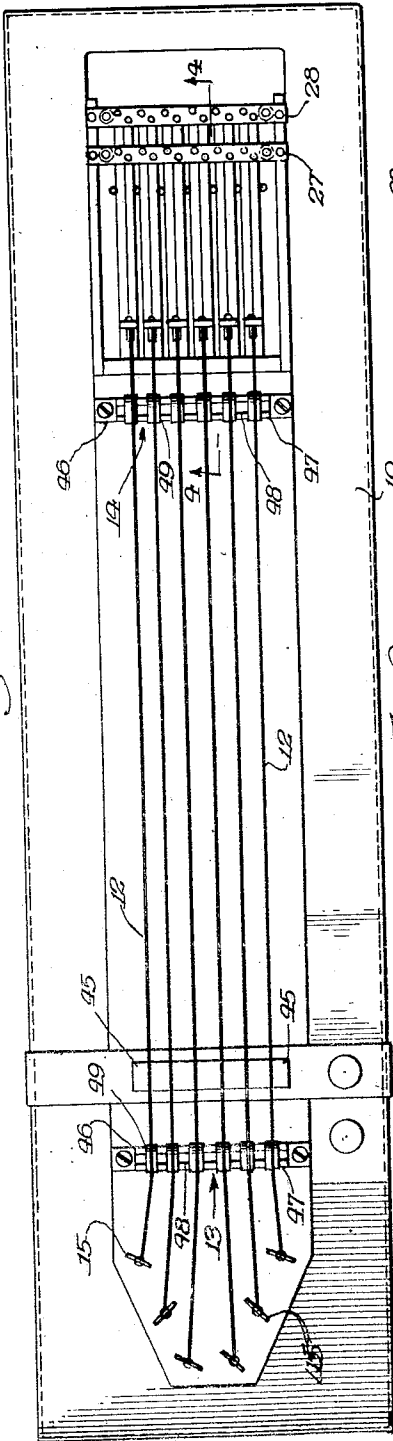

FIG. 2.

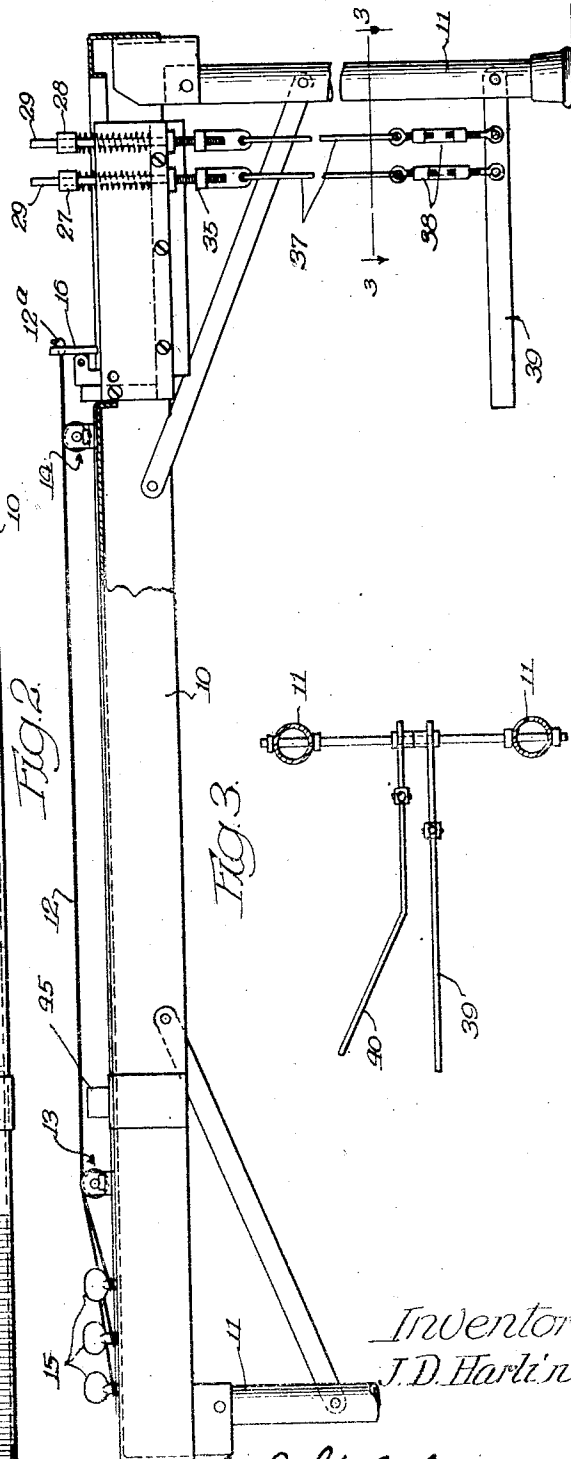
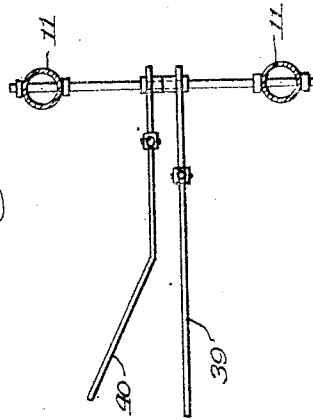

FIG. 3.



Inventor  
J. D. Harlin

By: Fred S. Gellach his Atty.



Jan. 4, 1949.

J. D. HARLIN  
STRING MUSICAL INSTRUMENT WITH  
CHORD TUNING MECHANISM

2,458,263

Filed Aug. 21, 1947

3 Sheets-Sheet 3

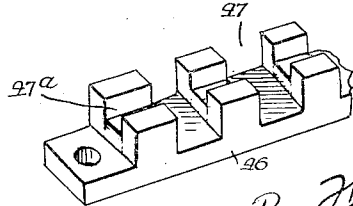
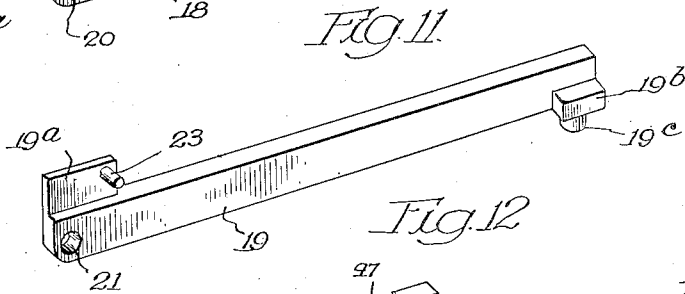
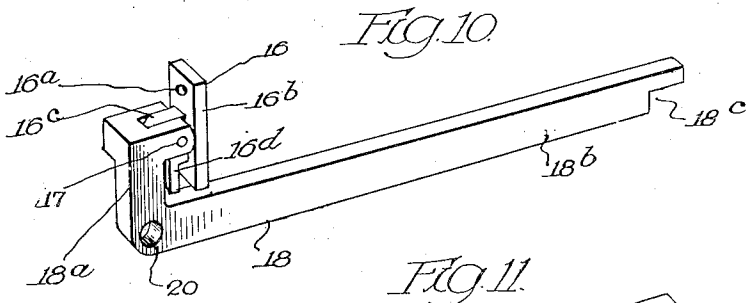
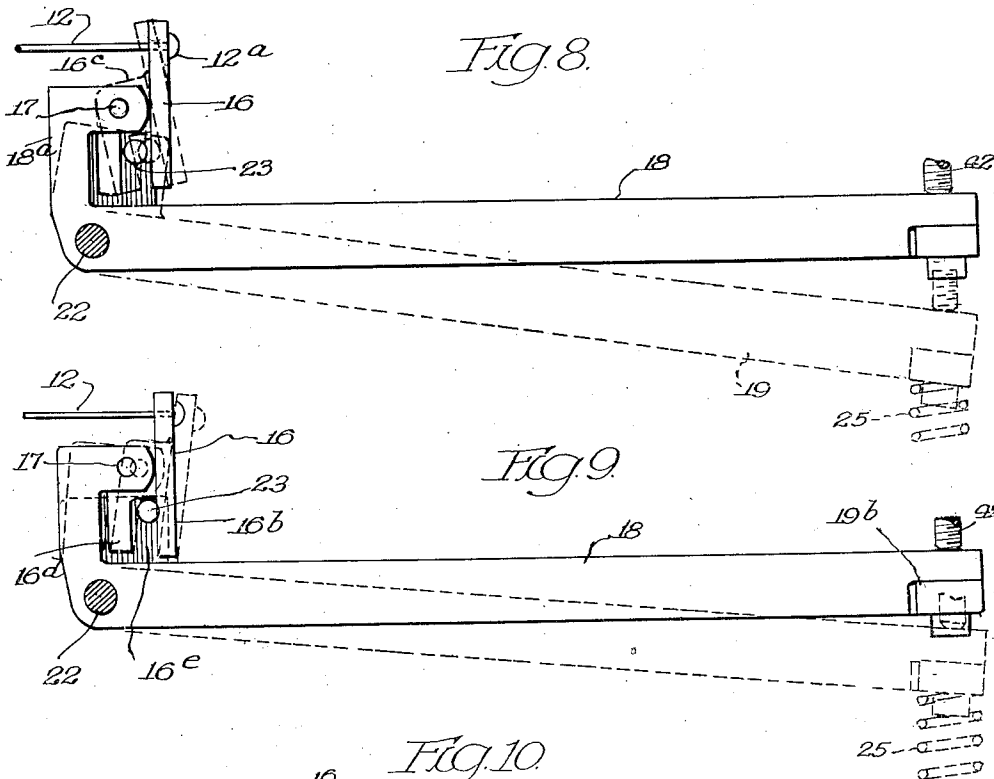

Inventor  
J. D. Harlin

By: *Thed Gerlach* his Atty.

# UNITED STATES PATENT OFFICE

2,458,263

## STRING MUSICAL INSTRUMENT WITH CHORD TUNING MECHANISM

J. D. Harlin, Indianapolis, Ind., assignor to Harlin  
Brothers, Indianapolis, Ind., a partnership

Application August 21, 1947, Serial No. 769,922

13 Claims. (Cl. 84—312)

1

This invention relates to string musical instruments and pertains more especially, although not exclusively, to such instruments as the guitar, mandolin, banjo and the like, which are played by picking or stroking the strings.

The primary object of my invention is to provide a stringed instrument on which one or more or several chords can be played without resort to difficult fingering operations which can otherwise be performed, if at all, only by skilled performers, thus making it possible for players having only rudimentary skill to give performances comparable to the performances of players of much greater experience and accomplishment.

To the above end I have devised a stringed instrument which is provided with one or more, usually several, sets of mechanisms each of which is adapted to be separately foot-actuated to vary the tension of the several strings or pre-selected ones thereof in such manner that when the several strings are stroked a definite predetermined chord is produced, no musical skill being required to play any chord the instrument has previously been set to produce.

My invention contemplates the addition to an otherwise more or less conventional stringed instrument of one or more mechanisms, each of which may be individually adjusted, as by means of adjustable actuating screws or the like, so that when it is brought into action, as, for example, by depressing a foot pedal individual thereto, certain strings of the instrument are consequently tightened while others may be slackened, or all may be tightened or all slackened, as the case may be; or certain strings may be tightened, others slackened and still others unchanged from their normal tension, depending entirely upon the make-up of the chord which it is desired to produce.

My invention contemplates any mechanism which is operative in response to a common actuating member simultaneously to alter the tension of a plurality of strings in such manner that the tension of certain strings is increased while that of other strings is decreased. But in its specific and more limited aspects my invention is characterized by the provision of a pivoted element or rocker for each string, to one and of which, individually, each string is anchored, and which functions upon rotation about a pivotal center either to tighten or loosen its attached string in conformity with the manner of its operation or direction of movement. To actuate the aforementioned pivoted element or rocker there are provided, in each instance, two operating levers

2

constituting a pair, of which there is one pair for each rocker, the levers of each pair being effective, conjointly, upon actuation, to tighten their respective strings, whereas one lever of each pair, when operated individually, is effective to cause a rotation of the associated rocker in a direction to slacken the tension of the attached string. By virtue of this arrangement it is possible selectively to vary the tension of the strings so that certain strings are tightened while others are slackened, all in response to a single operation of a common actuating member, such, for example, as a foot pedal.

Another novel feature of my invention lies in the means which I have devised for actuating the several pairs of levers in unison so that the tension of a plurality of strings can be varied simultaneously in accordance with a preconceived plan. This feature is characterized by the provision of a cross-bar which overlies and extends transversely of the several pairs of levers of a given set and carries a plurality of pairs of lever-actuating screws which are individually adjustable, one screw of each pair being capable, when suitably adjusted, or depressing both of a given pair of levers while the other screw of said pair is capable of depressing only one lever of the said pair. By selectively adjusting said screws the player can set the instrument for the playing of any desired chord or, alternatively, the adjusting of said screws can be carried out by the instrument manufacturer.

Additional objects and novel features of this invention will be apparent from the ensuing detailed description.

In the accompanying drawings (3 sheets) I have illustrated, by way of example, an application of my instrument to a stringed musical instrument of special design, the musical output of which is similar to that of a guitar.

Referring to the drawings:

Fig. 1 is a plan view of the instrument;

Fig. 2 is a side elevational view of the same;

Fig. 3 is a fragmentary sectional view taken at line 3—3 of Fig. 2;

Fig. 4 is an enlarged longitudinal sectional view taken at line 4—4 of Fig. 1;

Fig. 5 is a fragmentary plan view of the string tension adjusting mechanism;

Fig. 6 is an elevational view, partly in section, taken at line 6—6 of Fig. 4;

Fig. 7 is a sectional view taken at line 7—7 of Fig. 5;

Fig. 8 is a sub-assembly detail view of a part of the mechanism which serves to vary the ten-

sion of one of the strings of the instrument preparatorily to the playing of a chord, this view serving to illustrate the manner in which the tension of a string is slackened for the purpose of lowering its pitch;

Fig. 9 is a view similar to Fig. 8 illustrating the manner in which the tension of a string is increased by depressing both of two levers which function conjointly to regulate the string tension;

Fig. 10 is a perspective view of a spring-tensioning lever with a rocker pivotally attached thereto;

Fig. 11 is a perspective view of a second spring-tensioning lever which, in combination with the lever of Fig. 10, forms a co-operating pair, there being one such pair of levers for each string; and

Fig. 12 is a fragmentary perspective view of the base member of one of the roller equipped bridges of the instrument.

The instrument illustrated comprises a sounding board 10 of rectangular configuration, as depicted in Fig. 1, which is supported from the floor by means of four legs—one at each corner—identified, each, by reference numeral 11. The height of the sounding board above the floor level is usually such as to suit the convenience of a player sitting alongside the instrument. But it may, on the other hand, be high enough to accommodate a standing player.

Six musical strings 12 are stretched lengthwise of the sounding board, overlying the same and spaced thereabove; and these rest on two bridges 13 and 14 which, in turn, are secured to the sounding board.

The left-hand end of each string 12, as viewed in Figs. 1 and 2, is attached to a tuning key 15, of which one is provided for each string—said keys being of the type ordinarily provided on guitars and other stringed instruments. The strings 12 are tuned in the conventional manner by turning keys 15.

The right-hand end of each string 12, as depicted in Figs. 1 and 2, is anchored to an individual rocker member 16—each string being passed through an aperture 16a in its associated rocker member and swaged to form an enlargement 12a for securing the same against withdrawal through said aperture. Each rocker member, while serving as an anchorage for one end of its attached string, also functions through appropriate manipulation to alter the tension of its string in the manner hereinafter described.

As shown most clearly in Figs. 8-10, inclusive, the rocker members 16, each consist of a rectangular metal plate 16b having an integral lug 16c which has a depending tailpiece 16d. The latter is separated from the adjacent face of plate 16b to form a slot 16e.

Each rocker member 16 is pivotally attached by means of a pin 17 to the short vertical arm 18a of a bellcrank lever 18, which comprises, in addition to said vertical arm, an elongated horizontal lever arm 18b. It will be observed that the vertical arm 18a is bifurcated to form two laterally spaced fingers between which the lug 16c is disposed. Each rocker member 16 is freely rotatable through a limited angle about its supporting pin 17 and it will be apparent that rotation of one of said rocker members in a counterclockwise direction, as viewed in Fig. 8, will cause a slackening of the tension of the attached string 12.

A second lever 19, shown in perspective in Fig. 11, is mounted immediately adjacent and at the far side of each lever 18. The levers 18 and 19 as combined in co-operating pairs, of which there

are six in this instance, one for each string. Levers 18 and 19 are provided with holes 20 and 21, respectively, by means of which they are mounted on a pin 22 which extends transversely of the strings 12 and is suitably supported at its two ends.

Lever 19 has an upstanding arm 19a to which is secured a horizontal pin 23 which projects into and fits within slot 16e. Said pin 23 bears against tailpiece 16d and serves to anchor rocker member 16 against counterclockwise rotation under the tension of its string 12, except when lever 19 is purposely depressed as presently will be explained.

Lever 19 is provided with a horizontally projecting integral lug 19b which underlies and normally contacts the right-hand end of lever 18. A notch 18c is cut in lever 18 to clear lug 19b, thereby allowing the upper surfaces of the horizontal arms of the two levers normally to lie flush with each other or approximately so.

In Fig. 8 the rocker member 16 and two associated levers 18 and 19 are shown in full lines in their normal positions, wherein the normal tension is applied to string 12. But in the same figure lever 19 is shown in dotted outline in a depressed position, lever 18 remaining in its normal posture. The depression of lever 19 causes pin 23 to move clockwise in an arcuate path about pin 22, thereby causing a counterclockwise rotation of rocker member 16 to the posture thereof in which it is depicted in dotted outline. This, obviously, results in slackening the tension on string 12. Assuming a controlled and appropriate degree of slackening of string tension, it will be apparent that the pitch of the string can thus be lowered to a predetermined value, which may be a sub-harmonic of the normal pitch.

In Fig. 9 the full line showing of the two levers is the same as that of Fig. 8, the rocker member assuming its normal posture, with consequent normal tension on string 12. But the dotted outline in Fig. 9 is intended to illustrate the result of depressing both levers 18 and 19 simultaneously, this being accomplished by directly depressing lever 18 only, since lever 19 is mechanically coupled to lever 18 by virtue of lug 19b which underlies the end portion of lever 18. It will be seen that when the two levers 18 and 19 of a given pair are jointly depressed, as illustrated in Fig. 9, the associated pin 23 remains in its normal positional relation to pins 17 and 22 and that rocker member 16 consequently revolves bodily about pin 22 in the clockwise direction and thus increases the tension on string 12.

The six pairs of levers, each comprising a lever 18 and a lever 19, are disposed in a common horizontal plane, as best depicted in Fig. 6, and are spaced apart in conformity with the spacing of strings 12. Spacing pins 24 serve to maintain the proper spacing between adjacent pairs of levers.

Each lever 19 rests on an individual coil spring 25 and is centered in the top of its spring by means of a boss 19c which projects downwardly from its free end. The springs 25 serve to hold levers 19 in their normal postures and thus to press pins 23 against the tailpieces 16d, thereby counteracting the tension of strings 12. At the same time and by virtue of the fact that the free ends of levers 18 rest on the lugs 19b, springs 25 also press upwardly against the said free ends of levers 18 and serve to hold the latter in normal posture whenever the strings 12 may be loosened or detached.

The tension of strings 12 is transmitted through rocker members 16 to the vertical lever

arms 18a and thence to the abutment plate 26, as depicted most clearly in Fig. 4.

There are shown in the drawings two cross-bars 27 and 28 overlying and extending transversely of the several pairs of levers 18 and 19. These cross-bars are vertically slidable bodily on guide pins 29 and 30, and each is supported upon and pressed upwardly by a pair of coil springs 31 and 32 through which pass a pair of draw rods 33, 34, which are attached at their upper ends to the cross-bars and threaded at their lower ends to receive yokes 35, the latter being secured to their respective draw rods by means of nuts 36, which facilitate vertical adjustments of the yokes.

Pivotally connected to each yoke 35 is a connecting rod 37, each of which is connected through a turnbuckle 38 to an individual foot pedal 39 and 40. Depressing either of the foot pedals causes a downward movement of the corresponding cross-bar against the pressure of springs 31 and 32. The maximum downward movement of a cross-bar is reached when it strikes the two side plates 41, as will be evident from an inspection of Fig. 6.

Each cross-bar is drilled and tapped to receive six pairs of actuating screws 42, each said pair consisting of one screw which is adapted to engage the top surface of a lever 18 and one screw which is adapted to engage the top surface of a lever 19. These screws are designed to be individually adjustable so that one or the other of each pair is effective to engage and depress its associated lever. A downward adjustment of only the left-hand screw of any pair, as viewed in Fig. 6, will cause the corresponding lever 18 to be engaged and depressed when the supporting cross-bar descends. This, of course, results in rotating both levers 18 and 19 about pin 22, because the free end of each lever 19 is coupled through its lug 19b with the associated lever 18. The outcome, as previously explained, is a tightening of the string connected to the actuated pair of levers. On the other hand, a downward adjustment of only the right-hand screw of any pair, as viewed in Fig. 6, will cause the corresponding lever 19 to be engaged and depressed when the cross-bar descends. In such case the associated lever 18 remains in normal posture because the coupling effected by lug 19b is not such as to cause lever 18 to follow lever 19, although the converse is true. As previously explained, a depression of lever 19 results in slackening the tension of the associated string.

In adjusting the instrument to play a proposed chord, the player or tuner depresses one of the pedals until the corresponding cross-bar reaches bottom—the actuating screws having usually first been backed off so that none of them touches its associated lever, and the instrument having been tuned in the usual manner of tuning stringed instruments, that is by means of keys 15. Then certain of the actuating screws 42, depending upon which strings require additional tensioning or slackening, are adjusted downwardly, one at a time, in conformity with the pitch changes needed in order to condition the instrument for playing the proposed chord.

The actuating screws carried by each cross-bar are thus adjusted to condition the instrument for a particular chord; and there may be provided as many cross-bars and actuating pedals as desired, within the limits of available space.

Although the instrument illustrated is shown equipped to be conditioned to play only two chords, I prefer usually to provide for the playing

of a larger number of chords, generally six. The means for doing so consists of six cross-bars and six pedals.

The above-described instrument may be and preferably is provided with a magnetic pick-up 45 by virtue of which the volume of musical output can be stepped up through the medium of an electrical amplifier.

Another feature of my invention resides in the two bridges 13 and 14. These each comprise a base member 46 secured to the sounding board and functioning, in each instance, as a support for a rod 48 on which are rotatably mounted six rollers 49, each of which is grooved peripherally to seat one of the strings 12. Said rollers rotate slightly on rods 48 as the strings resting thereon stretch and slacken, thus eliminating or greatly reducing abrasion of the strings and the contacting bridge surfaces, and the life expectancy of the strings is, in consequence, materially increased. In Fig. 12 there is shown a perspective view of one of the base members 46 which, it will be seen, is milled to form a plurality of slots 47 for the reception and positioning of rollers 49. Said base members are also milled to form, in each case, a longitudinal slot 47a for reception of the associated rod 48.

It is thought to be self-evident to those skilled in the art that there are many possible modifications and alternatives within the scope and purview of my broad inventive concept and, accordingly, I do not wish to be limited otherwise than as clearly indicated by the terms of the appended claims.

Having described my invention what I claim and wish to secure by Letters Patent is:

1. The combination in a musical instrument, of a group of laterally spaced strings, means for anchoring each of said strings at one end of the group, a plurality of rocker members, one for each of said strings individually, each of said rocker members being attached to its individual string and effective upon being rocked in one direction to increase the tension of its string and, upon being rocked in the opposite direction, to slacken the tension of its string, a cross-bar associated with said rocker members conjointly, and means including a plurality of pairs of actuating screws for actuating said rocker members in response to a movement of said cross-bar, said pairs of screws being individually associated with said rocker members, one screw of each pair being effective, when suitably adjusted, to cause a movement of its associated rocker member in a direction to increase the tension of its attached string, the other screw of each pair being effective, when suitably adjusted, to cause a movement of its associated rocker member in a direction to slacken the tension of its attached string.

2. The combination in a musical instrument, of a group of laterally spaced strings, means for anchoring each of said strings at one end of the group, and a plurality of tuning units, one for each string, each said tuning unit including a rocker member together with a first lever and a second lever, said rocker member being attached to one of said strings and operative alternatively to increase and decrease the tension thereof in accordance with the direction of its movement, said rocker member being pivotally mounted upon and carried by said first lever, said second lever being normally operative, conjointly with said first lever, to lock said rocker member in its normal posture wherein it maintains normal tension

7

on its string, said second lever being operative, upon being moved from its normal posture independently of said first lever to relax its hold on said rocker member and thereby allow said rocker member to rotate in a direction to slacken the tension of its string, said first and second levers being effective, upon conjoint movement, to move said rocker member in a direction to increase the tension of its string.

3. The combination in a musical instrument, of a group of laterally spaced strings, means for anchoring each of said strings at one end of the group, a plurality of tuning units, one for each string, each said tuning unit including a rocker member together with a first lever and a second lever, said rocker member being attached to one of said strings and operative alternatively to increase and slacken the tension thereof in accordance with the direction of its movement, said rocker member being pivotally mounted upon and carried by said first lever, said second lever being normally effective, conjointly with said first lever, to lock said rocker member in a normal posture wherein it maintains a normal tension on its string, said second lever being operative, upon being rotated out of its normal posture independently of said first lever to relax its hold on said rocker member and thereby allow said rocker member to move in a direction to slacken the tension of its string, said first and second levers being effective, upon conjoint rotation in a given direction to move said rocker member in a direction to increase the tension of its string, and means operative to actuate said tuning units simultaneously, said last-mentioned means including a manually movable member and a plurality of pairs of actuating elements, one pair for each tuning unit, one element of each pair being operative, when suitably adjusted, to rotate both said levers conjointly and thereby increase the tension of the related string, the other element of each pair being operative, when suitably adjusted, to rotate said second lever only and thereby slacken the tension of said string, said elements being movable simultaneously by said manually movable member.

4. The combination in a musical instrument, of a group of laterally spaced strings, means for anchoring each of said strings at one end of the group, a plurality of tuning units, one for each string, each said tuning unit including a rocker member together with a first lever and a second lever, said rocker member being attached to one of said strings and operative alternately to increase and slacken the tension thereof in accordance with the direction of its movement, said rocker member being pivotally mounted upon and carried by said first lever, said second lever being normally effective, conjointly with said first lever, to lock said rocker member in a normal posture wherein it maintains a normal tension on its string, said second lever being operative, upon being rotated in a given direction out of its normal posture independently of said first lever to relax its hold on said rocker member and thereby allow said rocker member to rotate in a direction to slacken the tension of its string, said first and second levers being effective, upon conjoint rotation in a given direction to move said rocker member in a direction to increase the tension of its string, and means operative to actuate said tuning units simultaneously whereby to tighten certain of said strings and slacken other of said strings, said last-mentioned means including a cross-bar extending transversely of

8

said tuning units and manually movable bodily toward and away from said tuning units, and a plurality of pairs of actuating screws carried by said cross-bar, one pair for each tuning unit, one said screw of each pair being operative in response to a movement of said cross-bar to rotate both levers of its associated tuning unit in a direction to increase the tension of the associated string, the other screw of each pair being operative in response to a like movement of said cross-bar to rotate only the second lever of its associated tuning unit in a direction to slacken the tension of the associated string.

5. The combination in a musical instrument, of a group of laterally spaced strings, and manually operable means effective through a single movement, simultaneously to tighten certain of said strings and to slacken certain others of said strings, said means including a plurality of pairs of actuating elements, one pair for each string individually, the two elements of each pair being independently adjustable so that only one or the other is effective, one element of each pair being effective, when suitably adjusted, to cause a tightening of the associated string in response to an actuation of said manually operable means, the other element of each pair being effective, when suitably adjusted, to cause a slackening of its associated string in response to an actuation of said manually operable means.

6. The combination in a musical instrument, of a group of laterally spaced strings, and manually operable means effective through a single movement simultaneously to tighten certain of said strings and to slacken certain others of said strings, said means including a manually movable bar and a plurality of pairs of actuating screws carried by said bar and movable therewith, each pair of screws being operatively associated with one of said strings, one screw of each pair being effective, when suitably adjusted, to cause a tightening of its associated string in response to a movement of said bar, the other screw of each pair being effective, when suitably adjusted, to cause a slackening of its associated string.

7. A tuning unit for a stringed musical instrument, comprising: a first lever constituting a bellcrank having a short lever arm and a long lever arm, a rocker member pivotally mounted on said short lever arm and adapted at one end for anchoring attachment to a musical string, a second lever having means engaging said rocker member and effective when said second lever is in normal posture to hold said rocker member against rotation under the tension of its attached string, and spring means normally holding both said levers in normal posture, the arrangement being such that when both said levers are rotated away from normal posture in a given direction against said spring means the tension of the attached string is increased, said tension being decreased when said second lever only is rotated away from normal posture in said given direction.

8. A tuning unit for a stringed musical instrument comprising: a first lever constituting a bellcrank having a short lever arm and a long lever arm, a rocker member pivotally mounted on said short lever arm and adapted at one end for anchoring attachment to a musical string, a second lever fulcrumed co-axially with said first lever, said second lever being disposed immediately adjacent said first lever and having an arm which is normally co-extensive lineally with the long arm of said first lever, said second lever having means engaging said rocker member and

effective when said second lever is in normal posture to hold said rocker member against rotation under the tension of its attached string, and spring means normally holding both said levers in normal posture, the arrangement being such that when both said levers are rotated about their common fulcrum away from normal posture in a given direction against said spring means the tension of the attached string is increased, said tension being decreased when said second lever only is rotated away from normal posture in said given direction about said common fulcrum.

9. A tuning unit for a stringed musical instrument comprising: a first lever and a second lever having a common pivotal center, a rocker member pivotally mounted on and carried by said first lever, said rocker member being adapted for attachment to one end of a musical string, a pin carried by said second lever and engaging said rocker member and effective when said levers are in normal posture to hold said rocker member against rotation under the tension of the attached string, said levers normally extending in parallel side-by-side relation from their common pivotal center, and spring means normally holding said levers in normal posture, said levers being effective, conjointly, when rotated in a given direction about their common pivotal center to move said rocker member so as to increase the tension of the attached string, said second lever being effective when rotated individually about said pivotal center in said given direction to cause a rotation of said rocker member in a direction to slacken the tension of said string.

10. A tuning unit for a stringed musical instrument comprising: a first lever and a second lever having a common pivotal center, a rocker member pivotally mounted on and carried by said first lever, said rocker member being adapted for attachment to one end of a musical string, said second lever having means engaging said rocker member and effective when said levers are in normal posture to hold said rocker member against rotation under the tension of its attached string, said levers normally extending in substantially parallel side-by-side relation from their common pivotal center, said levers being effective, conjointly, when rotated in a given direction about their common pivotal center to move said rocker member so as to increase the tension of the attached string, said second lever being effective when rotated individually about said pivotal center in said given direction to cause a rotation of said rocker member in a direction to slacken the tension of said string.

11. A tuning unit for a stringed musical instrument comprising: a first lever and a second lever having a common pivotal center, a rocker member pivotally mounted on and carried by said first lever, said rocker member being adapted for attachment to one end of a musical string, said second lever having means engaging said rocker member and effective when said levers are in normal posture to hold said rocker member against rotation under the tension of its attached string, said levers normally extending in substantially parallel side-by-side relation from their common pivotal center, a portion of said second lever underlying said first lever so that said second lever is rotatable by said first lever in one direction, said levers being effective, conjointly, when rotated in said one direction about their common pivotal center to move said rocker member so as to increase the tension of the attached string,

said second lever being rotatable individually in said one direction and effective when so rotated to cause a rotation of said rocker member in a direction to slacken the tension of said string.

12. The combination in a stringed musical instrument, of a group of laterally spaced musical strings, means for anchoring said strings at one end of the group, a plurality of tuning units, one for each string, located adjacent the end of said group remote from said anchoring means, each of said tuning units comprising a first lever, a second lever and a rocker member, said rocker member being pivotally mounted on and carried by said first lever and attached to one end of one of said strings, said second lever having means engaging said rocker member for normally holding said rocker member against rotation under the tension of the attached string, said levers having a common pivotal center and normally lying in substantially parallel side-by-side relation, said levers being operative, conjointly, when rotated in a given direction, to move said rocker member in a direction to increase the tension of said string, said second lever being operative when moved independently of said first lever and in said given direction from normal posture to rotate said rocker member to slacken the tension of said string, a cross-bar extending transversely of said tuning units and movable bodily toward and away from said units, and a plurality of pairs of actuating screws carried by said cross-bar, one screw of each pair being operative, when suitably adjusted, to move both said levers in said given direction in response to a movement of said cross-bar, the other screw of each pair being operative, when suitably adjusted, to move said second lever in said given direction independently of said first lever in response to a like movement of said cross-bar.

13. A chord producing unit adapted for use with, and to form a part of, a stringed musical instrument of the type that embodies a substantially horizontal sounding board and has a plurality of parallel, spaced apart, tensioned strings a small distance above the board, said unit comprising a supporting structure mounted on the sounding board and provided with a pair of laterally spaced, upstanding side plates adjacent the strings, a crossbar extending transversely of the strings and between the side plates, provided with means between it and the supporting structure whereby it is mounted for limited vertical sliding movement in a truly rectilinear path and having associated therewith means whereby it may be operatively connected to any one or all of the strings in such manner that sliding movement thereof in one direction changes the tensioning of the strings to which it is operatively connected, pedal type means for sliding the crossbar in said one direction, and spring means between the supporting structure and the crossbar for urging said crossbar in the opposite direction.

J. D. HARLIN.

#### REFERENCES CITED

The following references are of record in the file of this patent:

#### UNITED STATES PATENTS

70 Number	Name	Date
2,234,874	Moore	Mar. 11, 1941
2,235,718	Maffei et al.	Mar. 18, 1941